

*Radiation Detection
for a Safer World*

Metal Recycling



 **Ludlum**
Measurements, Inc.

www.metals.ludlums.com

Ludlum Measurements



Radiation Detection for a Safer World

The Radiation Threat is Real

Guarding against radioactive sources poses a real challenge to metal recycling facilities all throughout the world. The economic harm and even potential health risk mandates a serious effort to ensure your facility and workers are kept safe. Despite efforts of governments to keep close tabs on all man-made radioactive sources, the reality is that there are thousands of known loose (orphan) sources that experts are willing to admit to. Given the ubiquitous nature of radiation as an effective tool in industry, medicine, research, electric generation etc., the likelihood of encountering unsuspecting sources is on the rise. Numerous accidents have already taken place resulting in severe economic impact and even death. Let there be no mistake about it, the threat to metal recyclers is growing and very real.



Catching Radiation is Challenging

Taking a measurement reading of a radioactive source is very simple and easily accomplished under laboratory conditions. Unfortunately, the stealth-like radioactive sources threatening to enter your facility will arrive under very different circumstances. Buried within a load of metal scrap, the radioactivity can become shielded in such a manner that detection becomes very challenging. The infinite shielding geometries, under which different source types and strengths arrive, pose a real physics challenge. Any company or person presenting a 100% guaranteed solution of detecting radiation under all possible conditions is either ignorant or hiding the truth. Catching radiation under real world metal recycling conditions is challenging and should not be underestimated or discounted. Ultimately, owners of these facilities need to choose a level of protection based on their own values of risk versus cost.

Ludlum Measurements Meets the Challenge

Ludlum Measurements, Inc. (LMI) has been designing, manufacturing, and supplying radiation detection and measurement equipment in response to the world's need for greater safety since 1962. Throughout its nearly five-decade history, it has developed radiation detection technologies and instruments in support of enhancing the safety of personnel and the environment. It offers one of the largest lines of radiation detection instrumentation available from any one company.

With thousands of metal scrap yard installations around the world, Ludlum has a proven track record of performance and reliability that uniquely places it as a leader in this field. Its reputation as a trusted partner and excellent after-sale support elevate Ludlum to a world-class organization ready to help you deal with the real world challenges you face.

Catalog Info

Index

Ludlum Measurements	2
Placing an Order	3
Ludlum Radiation Detection Experience & Expertise	4,5
Personal Touch Customer Care	6,7
Understanding Some Radiation Detection Basics	8,9
3 Stages of Detection	10
Radiation Protection Points	11
Gateway Monitors	
Model 4525-Series	12,16
Model 375P-1000V	17
Conveyor Monitor	
Model 375P-3500	18
Area Monitor	
Model 375-10 and Accessories	19
Baghouse/Scale Monitor	
Model 375-600	20
Slug Sample Counters	
Model 2100	21
Model 2100-1	21
MicroR Meters	
Model 2401-S	22,23
Model 19	22,23
Model 192	22,23
Model 193-6	22,23
Model 3 w/44-2	22,23
Isotope Identifiers	
Model 702	24
Model 703	24
Radioactive Sources	25
Support Services.....	26
Warranty	27

Placing an Order

Phone: 800-622-0828 325-235-5494
Fax: 325-235-4672
Email: ludlum@ludlums.com

www.metals.ludlums.com



Ludlum Radiation

Radiation Detection Product Lines

- Survey Meters
- Radiation Detectors
- Contamination Systems
- Area Monitors
- Air Monitors
- Dosimetry
- Sample Counting Systems
- Test Equipment
- Software
- Check Sources
- Emergency Response Kits

Ludlum offers one of the largest selections of radiation detection instruments in the world, all designed and manufactured by a single company.



Over 2500 Gate Monitoring Systems Installed Worldwide

- Proven Performance
- Demonstrated Reliability
- 24/7 Support



Detection Experience & Expertise

Serving Multiple Markets since 1962

Nuclear Power
Metal Recycling
Nuclear Medicine
Homeland Security
Research
Industry

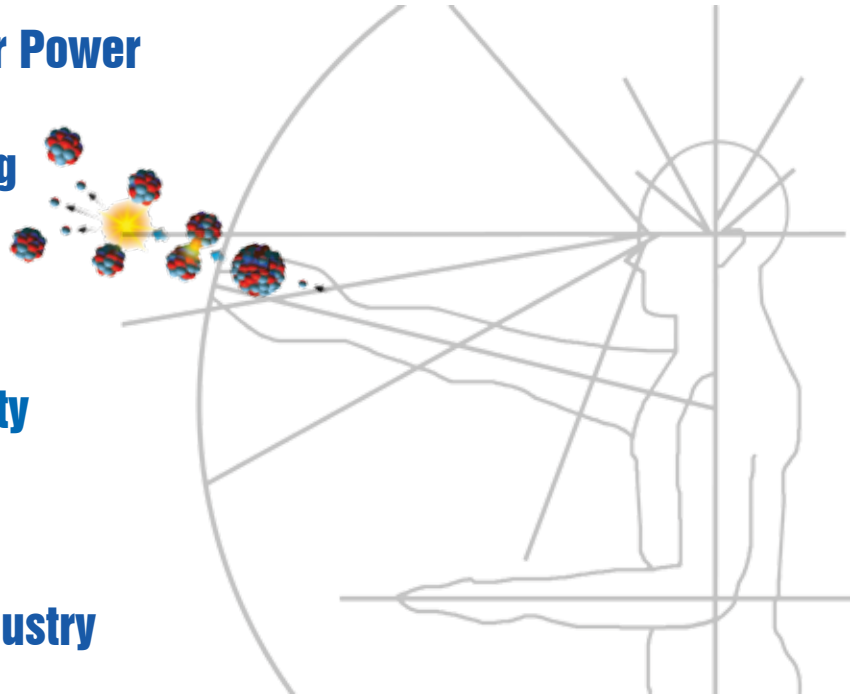

In-house Design & Manufacturing Yields Better Cost Control

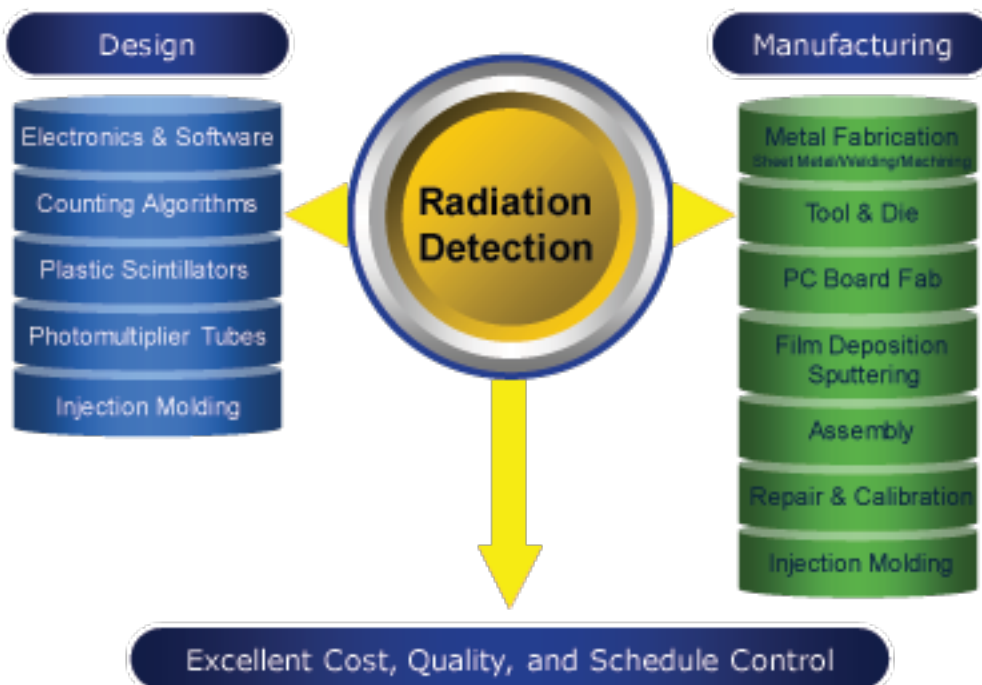

Ludlum does most of its own design and manufacturing. Its ability to do virtually all the work in-house affords extraordinary cost control others find difficult to beat. It furthermore facilitates better control over quality and manufacturing schedules.

Ludlum is proud of its ability to control its operation this effectively which is demonstrated by publicly posting its pricing.



Meeting Your Needs

Most of our customers depend on our expertise and assistance at one or more levels. Ludlum is organized and oriented at delivering the care and attention needed by our customers.

Ludlum's founder believes that servicing customers is as important as supplying the equipment. This simple philosophy has become an integrated component of the company that remains operative today, nearly a half century later.

So whether you are approaching your project for the first time or are now seeking to replace/upgrade an existing system, Ludlum is ready to take you from wherever you are to a fully operating and well maintained system optimized to fit your specific needs.

Product Selection

Product Purchase

Installation

System Setup & Calibration

System Training

24/7 Support



Personal Touch Customer Care



ation



Understanding Some Ra



Understanding Basics Is Helpful

Radiation physics is a complex subject; however, the basic principles at a practical level are not hard to grasp. Understanding a few basic principles can greatly assist in distinguishing between the different types of instruments Ludlum offers and why each is better suited for a given operation or function. It will also help you to better appreciate the difficult challenges you face in protecting your facility.

Radiation is Everywhere

This universe is built upon a nuclear structure that emits energy as it decays. The energy can be in the form of alpha, beta, gamma and neutron radiation. Gamma radiation is almost always present in any decay activity, can travel far distances, easily penetrate human tissue, and do real harm. Gamma radiation is therefore the primary radiation activity that metal recycling facilities outfit themselves to detect.

Gamma radiation surrounds us everywhere and comes from terrestrial and cosmic sources. Higher elevations receive higher levels of gamma radiation simply due to their closer proximity to the heavens above. Terrestrial sources range from natural earth materials (NORM) to man-made nuclear isotopes. While man-made sources are those you are guarding against, NORM can also become a nuisance and interfere with routine operations.

Detector Size and Coverage

Gamma radiation originates from the atom level (small point) and radiates outwardly in all directions in spherical fashion, producing a radiation field. Gammas cover a broad spectrum of energies, ranging from very weak to highly energetic. With only air in its path, and no other obstruction, gamma radiation will travel freely in distances that are proportional to its energy level. Dense scrap metal, on the other hand, can shorten the travel distances immensely, distort the surrounding radiation field, collimate the radiations to a very narrow streaming beam, or stop it altogether!

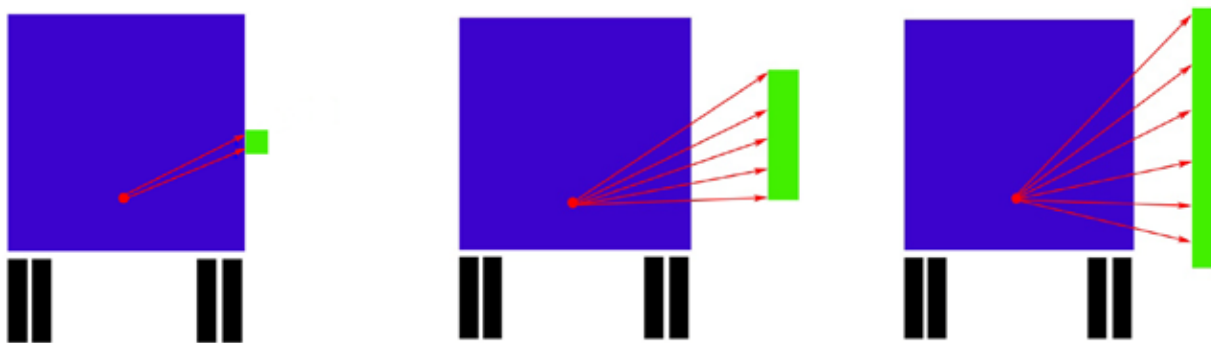

Small Size Detector

Medium Size Detector

Large Size Detector

Placing a small sized gamma detector at any point within a gamma radiation field will result in exposure to a relatively small portion of the overall radiations. In real-world metal recycling conditions, a uniform shaped radiation field (sphere) will rarely, if ever, exist, and will, therefore, be highly distorted or directional. A small sized detector will in all probability miss the radiation. As the diagram above depicts, a larger detector has a greater probability of seeing the radiations.

Radiation Detection Basics

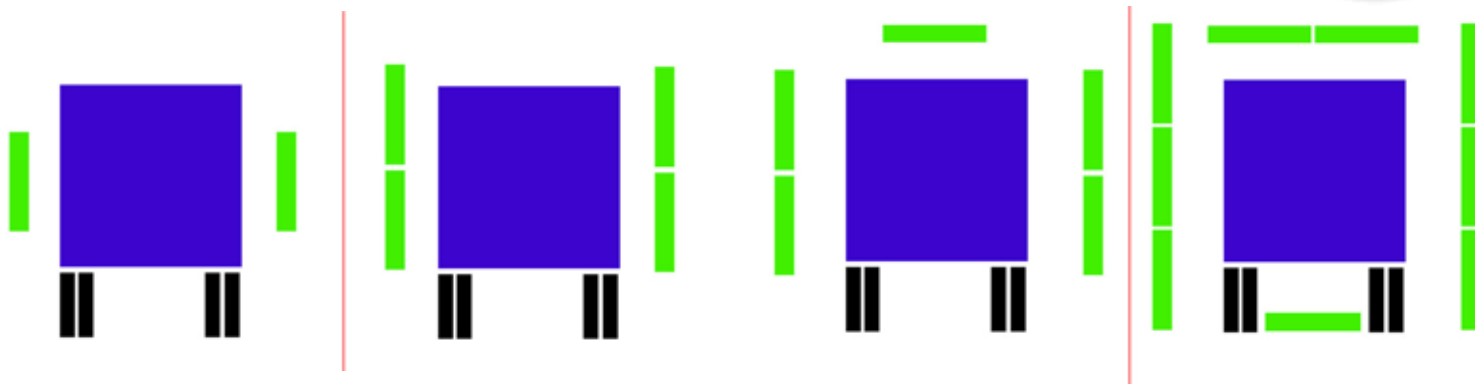

By adding more of the large size detectors, you get greater coverage, enhancing your probability even more. The takeaway principle is easy to grasp; large detectors and more detector coverage results in greater probability of detection.

Shielding

As already mentioned, shielding can be a serious deterrent to seeing gamma radiation. Non-ferrous metals, being less dense, produce less shielding than the more dense ferrous metals. Lead, due to its density, is commonly used to transport man-made sources with higher activity to lessen the penetrating gammas that can cause bodily harm. Any deliberately shielded sources inadvertently disposed of inside a load of ferrous scrap will present a much greater detection challenge but represents a real-world scenario. So shielding is always a major concern.

Distance

Radiation loses its energy as it travels through space until it gives it all up or is stopped by some material. The loss of energy over distance in free air (no obstructions) occurs at a predictable rate by the inverse square law which basically states that it loses its strength by the square root of the distance. All this is to simply say that the greater the distance the detector is from the radiation source origination point, the weaker the radioactivity becomes. Thus detector efficiency is always best when in immediate contact with the radiation source and then steadily becomes less with increasing distance.

Time

Time is another key factor in radiation detection. Radiation is random, meaning the emissions from the atom do not occur in a precise, repeatable fashion, as the second hand movement on a clock. It's simply random, so a detector exposed to a radiation source for a period of one minute might get 1000 counts the first minute, 987 the second minute, 1085 the third, 1043 the next, and so on. To overcome these naturally occurring fluctuations, longer count times are employed to obtain better statistics. Why is this important? Because the difference in the number of counts acquired between a radioactive source buried and shielded inside a load of scrap, and that from an empty load where only natural cosmic and terrestrial background are available, represents only a few counts difference. Longer counting times result in more assured decisions on whether the load is clean or not. Economics, however, mandate a proper balance between optimum count times and maintaining productivity.

3 Stages of Detection

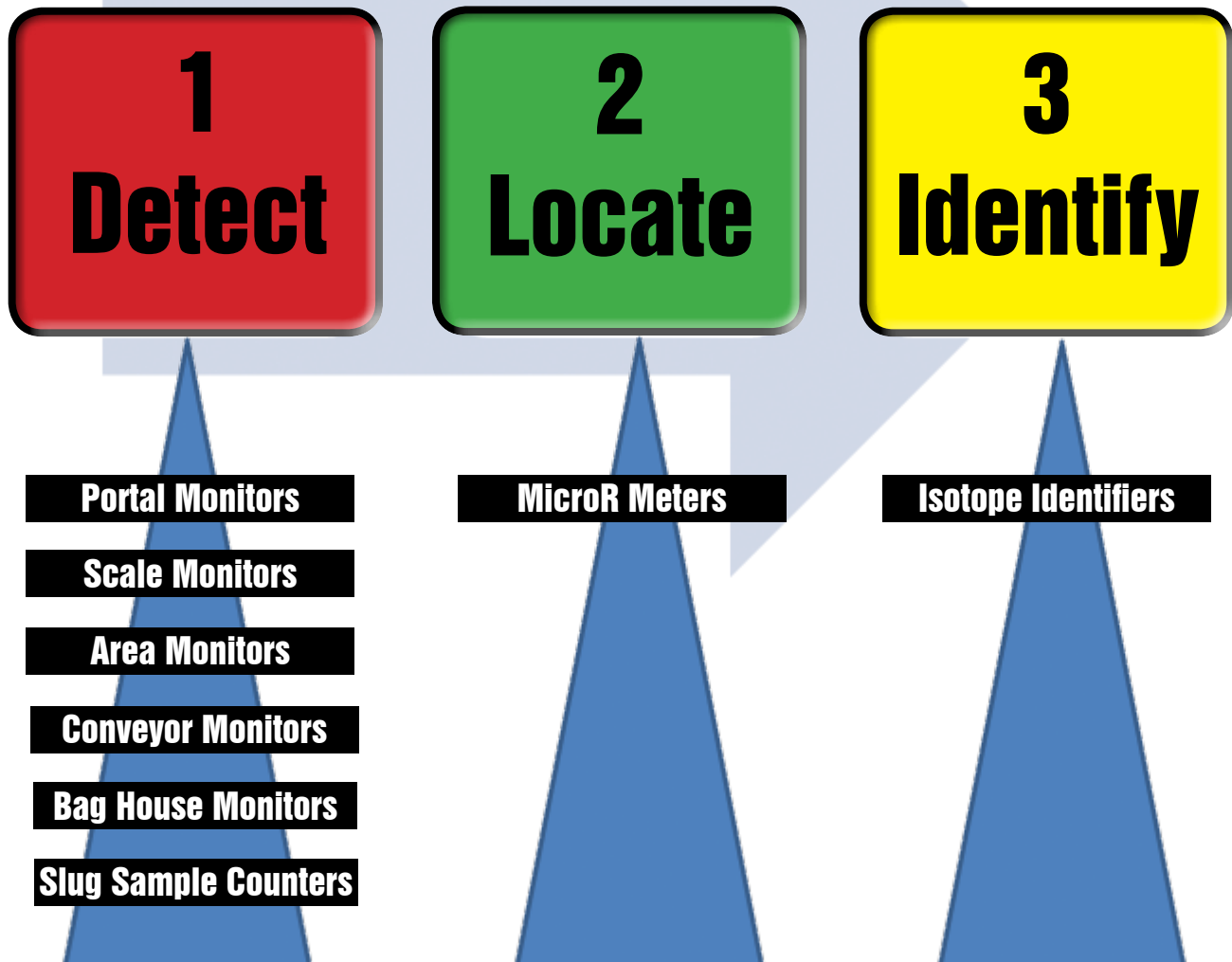

Radiation detection is available in three stages to facilitate all the needs of metal recycling and smelting facilities.

- 1. Detect** a primary class of instruments installed at a facility that are designed to detect and immediately notify you so a timely response and action can be initiated
- 2. Locate** a secondary class of hand-held portable instruments designed to locate the offending source so it can be removed from your facility
- 3. Identify** a final class of instrument designed to identify the radioactive isotope that will enable you to better assess the danger and action required

Radiation Protection Points

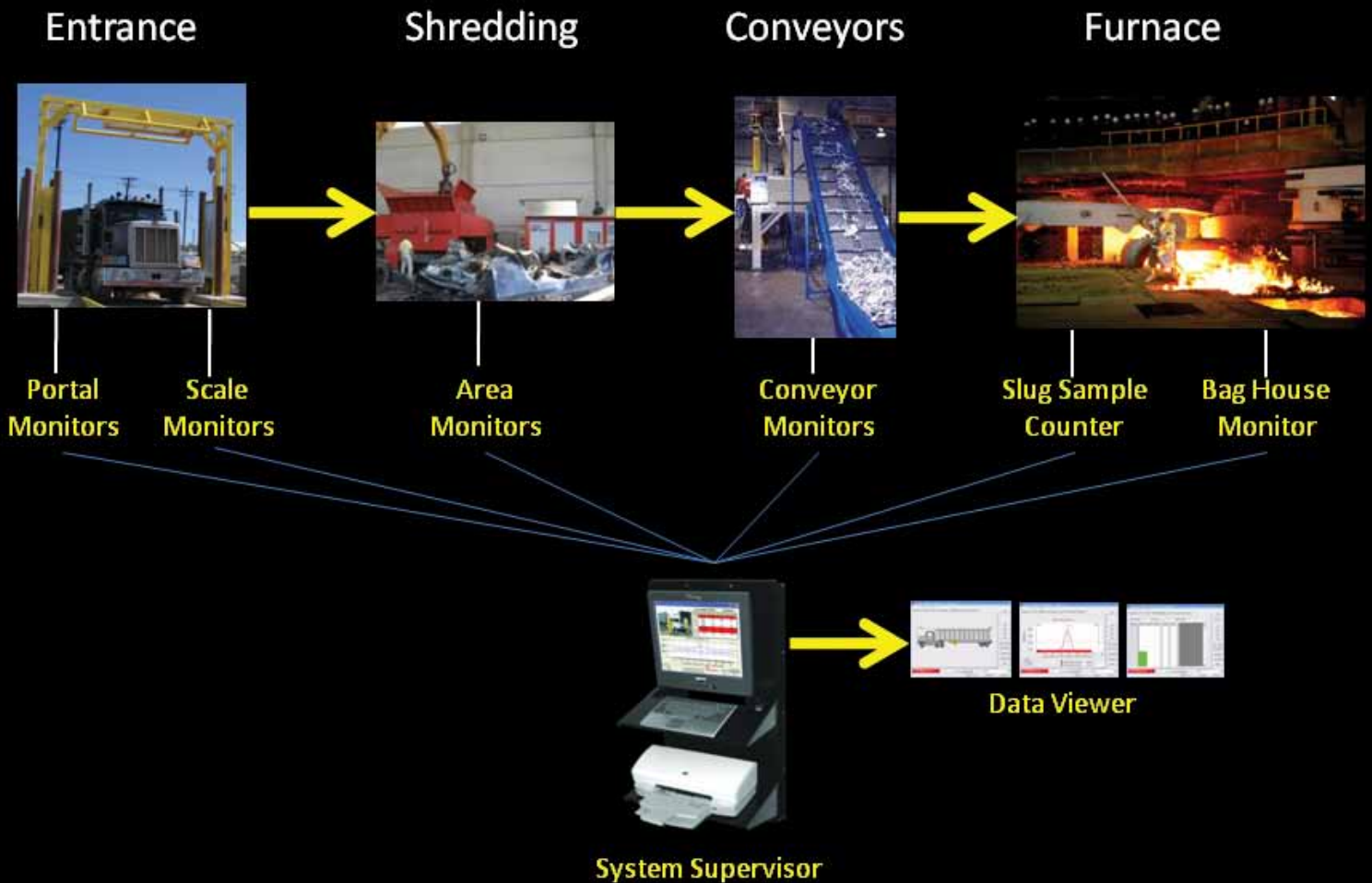

Do Not Limit Your Protection

Radiation protection is not limited to the entrance point of your facility. There are many points along the recycling process that offer additional protection worth consideration. While stopping radiation at the entry point, is the most desirable, it is also the most difficult point given the infinite geometries resulting from source-to-detector distances and shielding challenges. Implementing added layers of protection following the entry point not only offer secondary assurances, but can also offer far better radiation detection conditions that will significantly decrease any probability of a source getting through.

Combining all the subsystems into a central network further protects your facility by delivering 24/7 attention to any alarm events or equipment failures. These systems deliver immediate notification to desired locations at your facility, document each occurrence for later reporting and analysis, and even send pager type e-mails to designated personnel.

For those who prefer to be safe rather than sorry, additional protection points are highly desirable and attractive.



Gateway Monitors

Model 4525-Series

Features

- Large size, high sensitivity, industrial duty detectors
- Reliable operation with very low false positives
- Flexible detector configuration
- Accommodates up to 4 lanes with 2-8 detectors
- Real-time central data logging, reporting, and alarms
- Bidirectional entry
- Railcar mode
- Optional camera to capture and log vehicle images
- User-friendly operation
- 8-hour battery backup
- Multi-language support

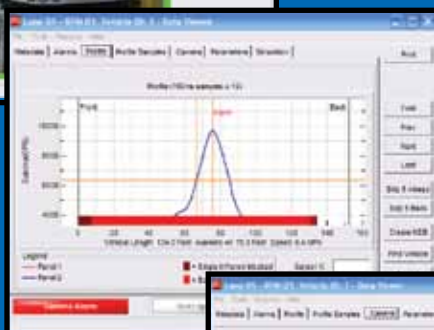
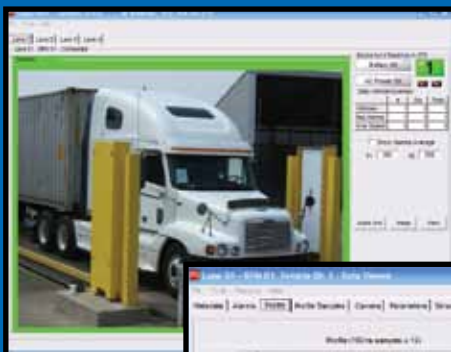
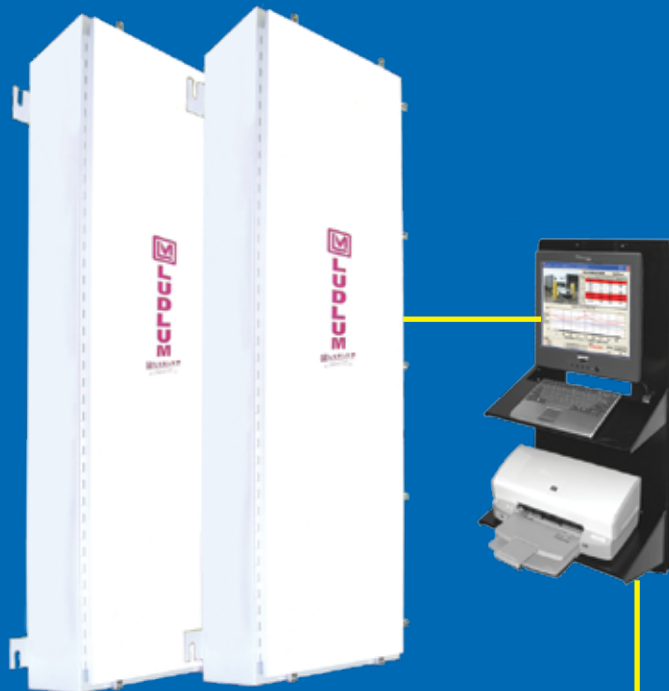

Network PC Software

Windows™ 7 Professional Operating System

Supervisor Software

- Real-time data collection
- Database archiving
- Alarm notification
- System control

Data Viewer

- Queries databases
- Print reports
- Creates databases on queries

Echo

- Runs on remote PCs
- Views all data



Gateway Monitors

Model 4525-Series



Introduction

The Ludlum Model 4525-Series of radiation gate monitors represents state-of-the-art technology at detecting orphan radiation sources. Ludlum has sold these types of systems throughout the world to scrap yards, recycling companies, landfills, and foundries.

The Model 4525 series of detectors are ruggedized, large, plastic scintillation systems that can be optimally arranged to monitor moving vehicles entering into the system. Each detector system can be configured with two to eight large detectors. Real-time data acquisition and analysis is performed directly at each detector system and then reported to a central PC for logging, reporting, and alarm notification.



Up to four detector systems (lanes) can be networked together via Ethernet or wireless to the central PC where vehicles entering from either direction can be monitored in real time. Each detector system additionally includes a remote control/annunciator panel to support operator awareness, alarm acknowledgement, and if necessary, backup operation in the event the central PC is unavailable.

Data from all the system sensors are acquired and checked by powerful, field-tested, and time-proven algorithms designed to check each load vigorously in a multi-dimensional, multi-layered manner before declaring any load as clean. Any abnormality is immediately alarmed and annunciated both locally and remotely.



An optional camera system can capture the image of the offending vehicle. The image is included in the logged data for permanent record keeping. Alarms can also be configured to automatically directly notify shift supervisors by e-mail, if desired.

The system is designed for ease of use and can be customized to accommodate a wide variety of site and application-specific criteria. Intuitive menus and controls combined with pre-defined automatic event handlers ensure each situation is handled properly and consistently.



Gateway Monitors

Model 4525-Series

Cost vs. Sensitivity Trade-off

Selecting the right system is dependant upon a number of factors. As the graph to the right depicts, greater sensitivity is obtained by adding detectors to increase the coverage. With added coverage and sensitivity comes an increase in cost. Balancing cost against risk is an independent judgement each customer is required to make.

Determining the best balance for your site is largely a function of the type of vehicles and density loading you expect through the gate monitor. The chart suggests the starting level system. More detectors can always be added up to a total of eight per lane.

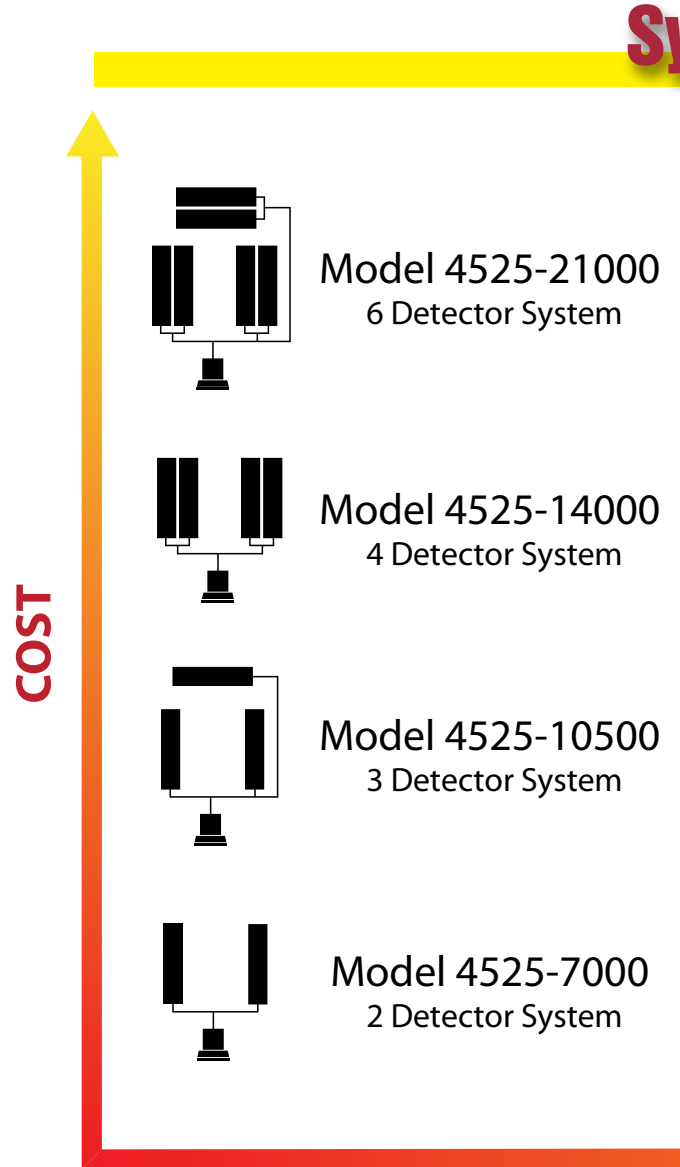

2 Detector System



Gateway Monitors

Model 4525-Series

System Selection Chart

Shipping containers

Railcars and heavy semi-trailers

Heavier shielded containers on semi-trailers

Pickup trucks, trailers and light semi-trailers

SENSITIVITY 



3 Detector System



4 Detector System



6 Detector System



Gateway Monitors

Accessories & Options



Remote Display

Unit is included with detector system. Comes with 30.5 m (100 ft) cable, audio annunciator upon alarm, and push button to silence and reset alarm.



Strobe / Horn

Includes 15 m (50 ft) cable
Part No: 4384-880



Wireless Point-to-Point

Connects Supervisor PC to detectors in the field
Part No: 4511-048



Camera

Displays high-speed IP video streaming, or static images (1280 x 1024 resolution)
Part Number: 2311120
Wireless connection option: Part Number 4511-556



Camera Housing

Weathertight, low profile, easy to mount camera housing with stand
Part Number: 21-9068

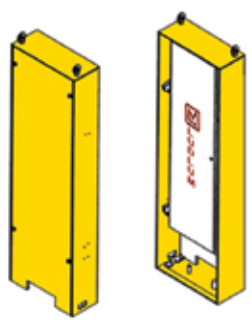

4525-Series
2 Detector Stand Set
Part Number: 4384-850

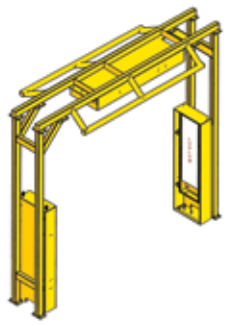

4525-Series
3 Detector Stand Set
Part Number: 4384-1003

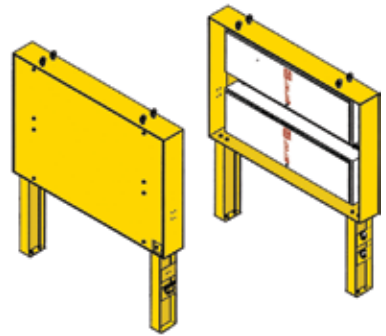

4525-Series
4 Detector Stand Set
Part Number: 4384-849

Detect

Gateway Monitors

Model 375P-1000V

Introduction

The Model 375P-1000V system is ideal for non-ferrous applications or where loads are very light, and the detector-to-load distance is short.

This system includes a digital Model 375 Controller coupled to two shielded 7866 cm³ (480 in³) plastic scintillator detectors. The detectors are encased in weather tight enclosures suitable for the outdoor environment, while the 375 Controller is normally mounted to a wall indoors near an operator.

This system includes vehicle presence sensors that detect whenever a vehicle is approaching so the controller can switch from background update mode to vehicle counting.

This simple and cost-effective solution offers a simple system that is easy to operate and maintain. The controller supplies local alarms, but can also be connected to external alarms or even put onto an Ethernet network, if desired.

Specifications

DETECTOR: 2 ea. 7866 cm³ (480 in³) plastic scintillation detectors with 0.32 cm (0.13 in.) lead shielding in weather tight housings

DISPLAY: 4-digit LED display with 2 cm (0.8 in.) digits

RESPONSE: typically 3 seconds from 10% to 90% of final reading

POWER: 95-135 Vac (178-240 Vac available), 50-60 Hz, 6-volt sealed lead-acid rechargeable battery

SIZE:

electronics: 26.2 x 24.6 x 8.4 cm (10.3 x 9.7 x 3.3 in.) (H x W x D)

detectors (ea.): 20.3 cm x 183 cm (8 x 72 in.) (Dia x L)

WEIGHT:

electronics: 4.2 kg (9.3 lb)

detectors (ea.): 29.5 kg (65 lb)



Features

- Affordable Digital Controller
- Weatherproof Encased-Shielded Plastic Scintillator Detectors
- Vehicle Presence Sensors
- Programmable Alarms
- Networkable
- 24-Hour Battery Backup

Detect

Conveyor Monitor

Model 375P-3500

Introduction

The conveyor radiation monitor has an advantage over gateway systems in that it allows the radiation detector to be exposed a few inches, not feet, from each piece of scrap while traveling under highly controlled conditions. This type of a scan offers an improved geometry and enhances detecting even weaker sources with much greater probability. The probability of detection at this secondary process is enhanced and is a very small price to pay for detecting any sources that may have escaped attention at the entry point.

Ludlum's conveyor radiation detection system employs its standard 3500 in³ scintillator detector, which is identical to that used in its popular gateway systems (see Model 4525 series). This detector delivers superior sensitivity while supplying commonality of parts and operation familiarity.

To reduce costs without compromising performance, the Model 375P-3500 system also utilizes Ludlum's highly popular Model 375 type controller that controls the detector, updates background, and carefully monitors the scrap metal passing by. The controller can operate totally independently, be wired for remote annunciation, or be connected to an Ethernet network.

Model 375P-3500 system includes:

- 1 ea. Model 375P electronics
- 1 ea. 57.4 L (3500 in³) plastic detector with 15.2 m (50 ft) cable
- 1 ea. 10 μ Ci check source

Optional Accessories include:

- 12.7 cm (5 in.) diameter red alarm strobe with 15 m (50 ft) cable
- 40 column date/time printer
- Model 271 wired remote
- Ethernet Kit



Features

Model 375 Electronics:

- User-Adjustable Alarms
- Electronics Housed in a NEMA 4X Enclosure with External Reset Button and See-Through Viewing Window
- Supplied with Mains Relay for Stopping Conveyor on Alarm, or Connecting Optional Alarm Strobe
- 24-Hour Battery Backup

Model 3500 Detector:

- Large Size Plastic Scintillation
- High Sensitivity
- Industrial Duty
- Weathertight, Lead-Shielded Enclosure



Area Monitor

Model 375-10

Gamma Area Monitor System

The Model 375-10 area monitor system is a self-contained unit that is easily hung on a wall. These can be hung in close proximity to any area where the scrap metal is either passing by or being processed as a secondary assurance measure.

This system employs an internally housed 5.1 x 5.1 cm (2" x 2 in.) NaI(Tl) scintillator type detector covering a range of 1-2,000 $\mu\text{R/hr}$. An Ethernet interface is standard on this unit to enable reporting any incidents in real-time to a central location. Several options are available for remote audible/visual annunciation, outdoor weather-proof enclosures, and more.



Optional Remote Indicators/Annunciators



271
Indicators

Part Number: 48-2475



272
Indicators/Meter

Part Number: 48-2656



272D
Digital Display

Part Number: 48-3575

Features

- Range: 0.1 - 20 $\mu\text{Sv/hr}$ (1 - 2000 $\mu\text{R/hr}$)
- Shielded Sodium Iodide (NaI) Detector
- User-Programmable Alarms
- Networkable
- 8-Hour Battery Backup

Ethernet Connectivity with a WebPage Interface

Model 375 controllers equipped with the Ethernet option can be connected to a radiation network that collects and displays radiation levels and alarm status in real time for up to 50 monitors. A standard webpage browser with appropriate authorization can view all data across the network and audibly annunciate any alarms. The system can also be set up to send intelligent e-mail alerts to responsible personnel and capture a picture of whatever triggered an alarm anywhere optional Ethernet cameras are employed.



Part Number: 1370-077



Current Status



Incident Summary

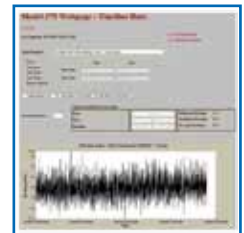

Timeline Data



Baghouse/Scale Monitor

Model 375-600

Introduction

The Model 375-600 is a highly integrated, high-sensitivity gamma measurement system. Unlike other systems where the detectors are separated from the controller and alarm indicators, this one combines all components into one convenient package, thus making installation simpler and less costly.

The detector employed is a 10.3 L (630 in³) plastic scintillator, which is shielded in all directions except beneath with 0.32 cm (0.13 in.) lead. The controller is Ludlum's popular Model 375 digital controller, which is integrated into one end of the cabinet.

A red strobe is mounted on the top along with a large, industrial strength alarm acknowledgement push button. The detector is accessible from a removable panel, and the entire system sits on a plate, which can be bolted to the floor.

Specifications

DETECTOR: 10.3 L (630 in³) shielded plastic scintillator

SHIELDING: 0.32 cm (0.13 in.) lead on 5 sides

SENSITIVITY: 30 kcpm/ μ R/hr (¹³⁷Cs)

DISPLAY: 4-digit LED display with 2 cm (0.8 in.) digits

DISPLAY UNITS: kcpm

RESPONSE: typically 3 seconds from 10% to 90% of final reading

POWER: 95–135 Vac (178–240 Vac available), 50-60 Hz, 6-volt sealed lead-acid rechargeable battery

BATTERY LIFE: typically 8 hours in non-alarm condition

TEMPERATURE RANGE: -15 to 50 °C (5 to 122 °F)

SIZE: 61 x 30.5 x 101.6 cm (24 x 12 x 40 in.) (H x W x D), base 61 x 101.6 cm (24 x 40 in.) (W x D)

WEIGHT: 60.8 kg (134 lb)



Features

- Integrated Measurement System
- Large Plastic Scintillation Detector
- Programmable Alarms
- Networkable
- Battery Backup



Slug Sample Counters

Model 2100-Series

Introduction

The Model 2100-Series sample counting system processes sample steel slugs to determine whether any radioactive impurities exist. The gamma radiation counting system is a table-mounted, fully integrated design that includes a gamma detector and controller.

Two models exist that are nearly identical with the only difference being the sample delivery to the detector. The **Model 2100** has a built-in conveyor with an infrared sensor that automatically initiates conveyance of the sample into the lead shielded detector where it is counted for a predetermined time. Once the count is completed, the conveyor again advances until the sample drops into a discard container. The **Model 2100-1** employs a standard manually operated sample drawer.

The counting electronics in both systems incorporate two channels to distinguish between low and high-energy gamma isotopes. All parameters, such as alarm point and count time are user adjustable from the front-panel LCD touch screen via a simple menu selection.

Measurement results for each sample are displayed on the backlit LCD. An Ethernet port reports all results and system status in real time for remote data logging and alarm annunciation. Visual and audible alarms are annunciated via the system's LCD and rear panel mounted buzzer respectively. An optional relay provides a method for driving an external horn/strobe.

One rear-panel, mounted USB port enables connection to either a keyboard or barcode reader device for the purpose of entering sample IDs.

Specifications

DETECTOR: 5.1 x 5.1 cm (2 x 2 in.) NaI (sodium iodide) scintillator

ENERGY RESPONSE: 30 keV to 3 MeV

SENSITIVITY: 0.1 Bq/g in less than one minute (standard 100 gram sample) (⁶⁰Co)

LEAD SHIELDING: internal lead shielding of 3.8 cm (1.5 in.) surrounds the detector chamber

BACKGROUND: ≈ 1200 cpm in the sum channel



Model 2100



Model 2100-1

Features

- High-Sensitivity Gamma Detector
- Separate High & Low Gamma Energy Sampling
- User-Adjustable Parameters
- Color LCD Touch Screen
- Ethernet Connectivity
- Remote Alarm Output
- USB Ports for ID Input Devices

Introduction

These portable survey meters facilitate finding the location of the offending source for extraction. In addition to the readout display, they all include an audible output that is proportional to the radiation activity, which helps in locating hidden sources.

Each of the systems presented below have sensitive gamma scintillator detectors. The key difference between each model is how sensitive they are. The chart to the right depicts their sensitivity, as noted in the specifications listed below. Other differentiators are price, and whether the detector is internal to the instrument or external to facilitate searching areas that might otherwise be difficult to reach.

Model 2401-S



- Internal Detector
- Pocket Size
- Sensitivity: 120 cpm/ μ R/hr
- 3-Decade Analog Meter

Part Number: 48-3177

Model 19



- Internal Detector
- Sensitivity: 175 cpm/ μ R/hr
- 5 Selectable Ranges
- Analog Meter with Backlight
- Fast & Slow Response Switch
- Model 19A available with built-in alarming capability

Part Number: 48-1615

Model 3



- External, Detachable
- Sensitivity: 175 cpm/ μ R/hr
- 4-Decade Analog Meter

Part Number: 48-1615

Locate

MicroR Meters

Sensitivity Chart

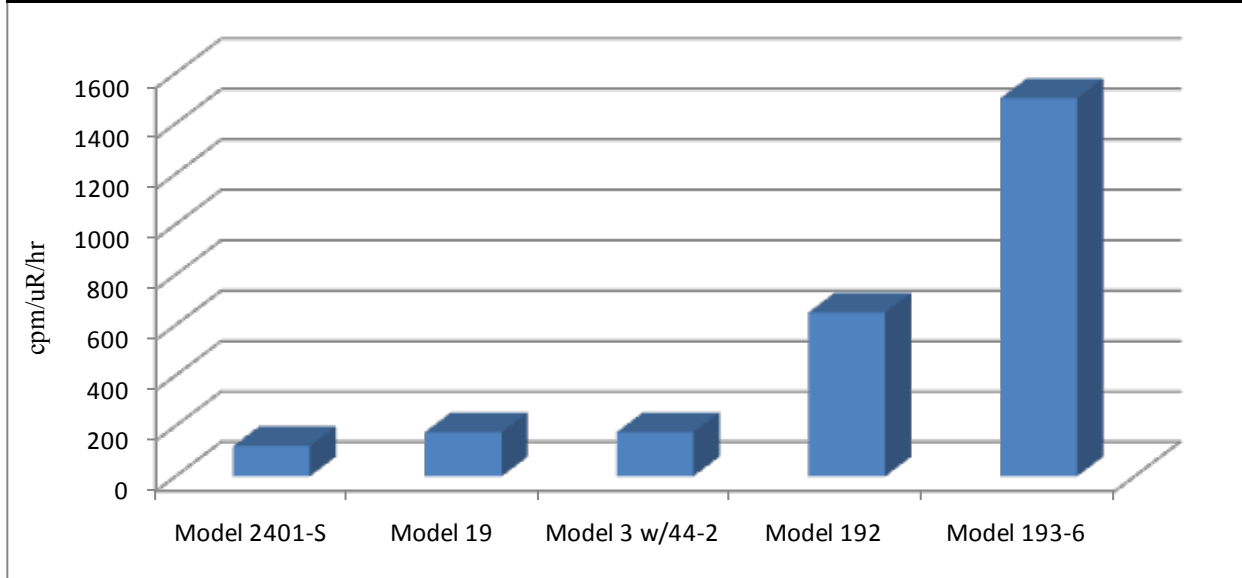

w/44-2



Removable Detector
5 cpm/μR/hr
Log Meter

Part Number: 48-1532 and 47-1532

Model 192



- Internal Detector
- Sensitivity: 650 cpm/μR/hr
- 4-Decade Analog Meter
- Fast & Slow Response Switch
- Meter Reset

Part Number: 48-2945

Model 193-6



- External Detector on 1.2 m (4 ft.) Pole
- Sensitivity: 1500 cpm/μR/hr
- 4-Decade Analog Meter
- Special Deviation Alarm

Part Number: 48-1615

Locate

Identify

Isotope Identifiers

Model 700-Series

Introduction

Isotope identifiers not only assist you in locating radioactive sources within a heap of scrap, but also identify the isotope to determine whether or not the radioactive material is man-made or natural. The 700 Series of identifiers are easy to use, field-deployable instruments capable of very quick and accurate isotope identification. They are equipped with color LCDs, store captured spectra to a built-in flash card, and include a copy of Quantum PC software.

Ludlum offers two different models for the metal recycling market. Both are identical except for the detector size and sensitivity. They are:

Model 702

Detector: 5.1 x 5.1 cm (2 x 2 in.) NaI(Tl) detector
Sensitivity: 1500 cps/mSv/h (900 cpm/ μ R/hr)

Model 703

Detector: 7.6 x 7.6 cm (3 x 3 in.) NaI(Tl) detector
Sensitivity: 3833 cps/mSv/h (2300 cpm/ μ R/hr)

Common Specifications

ENERGY RANGE: 18 keV–3 MeV

DISPLAY: 320 x 240 pixel, color LCD

POWER: 8 standard NiMH AA batteries and spare battery holder included; alkaline AAs can also be used, universal AC power adapter included

WATER/DUST RESISTANCE: IP56

TEMPERATURE RANGE: -20 to 50 °C (-4 to 122 °F)

RELATIVE HUMIDITY: < 95%

EASE OF USE: setup options can be password-protected for use by non-technical personnel

CONTROLS: seven-key custom keypad with one-thumb operation

ALARM: visual (on screen) and audio (internal speaker or optional headphones)



Features

- Quick Identification with High Accuracy
- Self Calibrating
- Sunlight Readable Color LCD
- Separate User & Advanced Operational Modes
- Single-Handed Operation
- ANSI N42-34 Compliant
- Removable Compact Flash Card Spectra Storage

Radioactive Sources

Radioactive Check Sources

It is very important to regularly verify operation of all your radiation detection instrumentation. This is best accomplished by placing radioactive check sources in proximity of the detector to induce a positive upscale reading. For those systems equipped with alarms, it is also desirable to ensure the system triggers an alarm and that all subsystems are properly functioning.

All the radiation check sources listed below are NRC exempt quantities and do not require any special permits or licensing within the USA. Their activity is low enough that it does not pose any health risk while checking instruments. They also do not require any special shielding for storage. The 0.25 μCi ^{137}Cs is the only source that can be shipped internationally from Ludlum.



Source	Size (diameter x thickness)	Part Number
0.25 μCi ^{137}Cs	2.5 cm x 2.5 mm (1.0 x 0.10 in.)	01-5723
1.0 μCi ^{137}Cs	2.5 cm x 2.5 mm (1.0 x 0.10 in.)	01-5196
5.0 μCi ^{137}Cs	2.5 cm x 2.5 mm (1.0 x 0.10 in.)	01-5186
10 μCi ^{137}Cs	2.5 cm x 2.5 mm (1.0 x 0.10 in.)	01-5231
1.0 μCi ^{133}Ba	2.5 cm x 2.5 mm (1.0 x 0.10 in.)	01-5818

Model 2100 Sample Counter Calibration Source

Ludlum has created this simulated ^{60}Co source for use with the Model 2100 and 2100-1 slug sample counters. The source is calibrated to produce 0.1 Bq/g (10 Bq) of activity.



Support Services



Repair

Our facility offers a full-service repair and calibration department. We not only repair and calibrate our own instruments but most other manufacturers' instruments as well. Repair estimates are offered at no cost, and repair and modification charges are based on material cost plus labor. Labor rates are billed for actual time at the currently published rates.



Calibration

Ludlum performs NIST traceable calibrations with compliance to ANSI N323. Standard instrument calibrations supply as-found readings and two points per range calibration for a single detector setup. Most special multi-detector and multi-source calibrations can also be performed on Ludlum designed instrumentation as well as many instruments manufactured by others.

Visit our website to view the current rates.



Training

Ludlum offers an intensive two-day training course that involves calibration, repair, and maintenance on Ludlum manufactured instruments. LMI offers this training at no charge at our facility in Sweetwater, Texas. Accommodations and meals must be provided by the attendees. Training is usually scheduled around mid-month, but other times can be accommodated especially for groups of four or more. Training is also offered at locations around the country in the spring and fall (see list of scheduled classes on our website). If you are interested in signing up for this training, please contact Randy Smith or Carlos Chapa at Ludlum Measurements, Inc. at 800-622-0828 toll free or 325-235-5494.

Warranty

Ludlum Measurements, Inc. warrants the products covered herein to be free of defects due to workmanship, material, and design for a period of 12 months from the date of delivery. The calibration of a product is warranted to be within its specified accuracy limits at the time of shipment. In the event of instrument failure, notify Ludlum Measurements, Inc. to determine if repair, recalibration, or replacement is required. This warranty excludes replacement of photomultiplier tubes, GM and proportional tubes, and scintillation crystals, which are broken due to excessive physical abuse or used for purposes other than intended. There are no warranties, express or implied, including without limitation and implied warranty or merchantability or fitness, which extend beyond the description of the face thereof. If the product does not perform as warranted herein, purchaser's sole remedy shall be repair or replacement, at the option of Ludlum Measurements, Inc. In no event will Ludlum Measurements be liable for damages, lost revenue, lost wages, or any other incidental or consequential damages arising from the purchase, use, or inability to use product.

Extended Warranty

Ludlum Measurements, Inc. now offers an Extended Warranty Plan on select models. For increased peace of mind and to compliment our standard warranty, Ludlum offers a solution that responds to your needs and fits your expectations. Keep your equipment in the best operating condition with our Extended Warranty Plan.

What it Offers:

- One-year extended warranty coverage beyond original factory warranty
- Priority Repair - we will expedite your repair ahead of non-extended warranty plan equipment
- Free firmware and hardware upgrades when available
- Notification of calibration due date, pending plan expiration date and update notice

How to Purchase:

You may purchase your Extended Warranty Plan at the time you order your new instrument or anytime within six months of original purchase date with proof of purchase from an authorized dealer. If purchasing after initial instrument purchase, please fill out an Extended Warranty Order Form, which is found at www.ludlums.com under Support and submit via e-mail (Ludlum@ludlums.com) or fax (325-235-4672).

When Your Coverage Starts:

As with our Standard Warranty, you will start receiving the benefits of your Extended Warranty Plan from the date of delivery. This includes priority repair handling and firmware/hardware upgrades when available. The extended warranty portion of your plan goes into effect at the end of your standard factory warranty period.

Terms and Conditions

You must purchase your Extended Warranty Plan at the time of instrument purchase or within six months of the instrument purchase. An Instrument Return Form must be submitted for any service, including while under an Extended Warranty Plan. Priority repair handling covered under the Extended Warranty Plan will warrant your instrument receives the next available service time. Your instrument is moved ahead of non-Extended Warranty plan equipment. This service will begin during your Standard Warranty as well as throughout your Extended Warranty. Extended Warranty Plans cover normal equipment repair concerns. Equipment showing signs of failure due to physical abuse, improper operation, or application as determined by our technicians are not covered under this Extended Warranty Plan, and standard repair and calibration charges will apply. Notifications of pending calibrations, plan expiration, and updates are dependent upon the contact information you list when purchasing an Extended Warranty Plan. Renewal plans do not receive a new Extended Warranty Plan #. Your coverage will be continued under your original Plan #. Extended Warranty Plans are renewable up to three years beyond the standard warranty as long as there has been continuous extended warranty coverage.



www.metals.ludlums.com

&

www.ludlums.com

501 Oak Street, P.O Box 810, Sweetwater, Texas 79556 USA

Voice: 800-622-0828, 325-235-5494 Fax: 325-235-4672

Email: ludlum@ludlums.com

Apr 2011